



product support

MASTER COPY

SERVICE BULLETIN

COLLINS RADIO COMPANY

SERVICE BULLETIN NO. 1

EQUIPMENT SERIES: 75S-3B/3C

February 27, 1967

Page 1 of 17

Revised 5-11-67

Revised 9-29-67

EQUIPMENT TYPE: 75S-3B/3C RECEIVER

SUBJECT: IMPROVED PERFORMANCE

The modification in this service bulletin concerns a change that has been made in present production 75S-3B/3C Receivers that improves performance in the presence of extremely strong signals, improves performance of the mechanical filters, improves CW operation and improves headphone audio quality.

The operating circumstances in which these improvements are readily apparent are somewhat limited, and the decision to modify an existing receiver should be made only after careful consideration.

To determine if your 75S-3B/3C Receiver has been modified, lift the top cover and observe the mechanical filter compartment. If the new magnetic shield is installed, as described in this service bulletin, the unit has had the modification installed.

Only those persons who have daily activity in electronics and access to adequate test bench facilities should attempt to perform this modification. Otherwise, receivers may be sent to an Authorized Service Agency or the Collins Factory Service Department.

The 3rd edition of the 75S-3B and 75S-3C Receivers Instruction Book will cover the changes described in this service bulletin.

The estimated time to complete this modification is 6.0 hours.

MODIFICATION PROCEDURE

1. Remove four feet and the screw located midway between rear feet from bottom of cabinet.
2. Remove two unpainted screws located under lid along front of cabinet.
3. Slide chassis from cabinet.
4. Carefully remove mechanical filters and tubes and store in a safe place.

5. Referring to figure 1 remove and discard the following components connected between the points given.

COMPONENT CONNECTED	FROM	TO
68K resistor R7	XV4 pin 2	J2 ground lug
68-ohm resistor R8	L3 pin 1	XV4 pin 2
1.8K resistor R59	TB2 pin E	TB2 pin J
100-ohm resistor R66	TB2 pin J	TB8 pin 3
15-pf capacitor C27	T3 pin 3	L3 pin 1
68K resistor R90	L3 pin 1	L3 pin 3
680-ohm resistor R71	XV5 pins 3	Ground
120-ohm resistor R72	XV5 pin 1	TB4 pin 2
47K resistor R69	XV6 pin 7	L9 pin 2 (Multiplier circuit)
68-ohm resistor R12	XV6 pin 7	R57 potentiometer
12K resistor R32	TB1 pin E	Grd 4
10K resistor R89	Across C127	
10K resistor R90	Across C152	
0.01-uf capacitor C86	XV6 pin 7	XV6 shield
Bus wire	XV6 pin 2	R57 pins 1 & 2 and S13 pins A & 1A
100-pf capacitor C41	XV7 pin 1	L9 (Multiplier circuit)
Bus wire	XV5 pin 3	XV5 pin 8
120-pf capacitor C83	XV3 pin 9	TB14 Terminal 2

6. Disconnect the lead attached to L9 pin 1.
7. Disconnect the 100K resistor R19 where it attaches to XV7 pin 1.
8. Disconnect 1000-ohm resistor R14 lead and the 0.01-uf capacitor C40 lead where they attach to L9 pin 2.
9. Remove and discard inductor L9.
10. Loosen the screw of the shaft coupler on the MODE switch shaft that is nearest the front panel.
11. Slide the phenolic shaft toward the rear of the chassis.
12. Disconnect the leads to switch S11.
13. Remove the MODE switch knob.
14. Remove switch S11. Save the hardware for mounting the new switch.
15. Remove and discard the phenolic shaft.

NOTE Do not allow any rotation of the switch sections during withdrawal. Save the shaft coupling for use on new shaft.

16. Remove two posts that support mechanical filter hold-down bar. Save mounting hardware for mounting parts in step 43.
17. Locate the right hand spade bolt that protrudes from the rear of PTO (precision tuned oscillator) as you face the front of the unit.
18. Remove the excess screw length from the spade bolt with a sharp hacksaw.
19. Position the receiver upside down with the front panel towards you.
20. Locate and center punch a hole 3/8-inch to the right of the center of J2 (figure 1).
21. Drill a 0.089-inch diameter hole using a number 43 drill bit.
22. Install terminal post TB24 (306-0981-000) with 2-56 X 3/16-inch screw (343-0298-000) and lockwasher (310-0074-000).
23. Refer to figure 2 and center punch the two hole locations.
24. Drill two 0.089-inch diameter holes using a number 43 drill bit.
25. From the top of the chassis (figure 1) locate and centerpunch a hole 3/16-inch to the left (when facing the front panel) of the left mechanical filter hold-down bar. Hole location will be to the rear of the PTO.
26. Drill a 0.147-inch diameter hole using a number 26 drill.
27. Locate and centerpunch two holes between XFL4 and XFL1 and between XFL2 and XFL3 for grd-20 and grd-21 as shown in figure 1. Use a number 4 ground lug (304-0317-000) to locate the hole. The connection point of the lugs should be placed close to the bus ground wire connecting the four filter sockets.
28. Drill two 0.134-inch diameter holes using a number 29 drill.
29. Deburr all holes by hand using a large drill or a countersink.
30. Mount two number 4 ground lugs (304-0317-000) at locations grd-20 and grd-21 using two 4-40 screws (343-0285-000), number 4 lockwashers (310-0076-000) and 4-40 nuts (313-0156-000). Position the connection point of the lugs close to the bus ground wire connecting the four filter sockets.
31. Solder connect grd-20 directly to the ground bus wire. Install short length of bus wire (421-2220-000) from grd-21 to pin 5 of XFL1 solder connection.
32. Mount IF transformer T9 (278-2080-010) in the location and with terminal positioned as shown in figure 3. Use two 2-56 X 1/4 screws (343-0299-000), number 2 lock washers (310-0074-000) and 2-56 nuts (313-0050-000).
33. Mount a number 4 ground lug grd-19 (304-0317-000) under the nut that secures the tab of tube socket XV5 located nearest the front panel.

34. Mount IF transformer T10 (278-0281-000) as shown in figure 3 in the former location of L9. Position terminals as shown.
35. Slide metal shaft (554-2559-002) halfway into the shaft coupling and tighten setscrew onto shaft.

NOTE Refer to figure 1 for location of major components.

36. Insert metal switch shaft (step 35), through the front panel and slide it on through the switch sections. Check that all switches have the indexing notch pointed in the same direction.
37. Install length of insulated bus wire (422-4312-000) from pin 6 to pin 2 of new switch S11 (259-2533-010).
38. Install the new switch S11 (259-2533-010) on the front panel with hardware removed from old switch in step 14.
39. Connect the original leads to the new switch S11, BFO switch lead to pin 6 of S11 and remaining lead to pin 5 of S11.
40. Attach knob to S11 (removed in step 13).
41. Check that indexing tab of S11 is pointed in the same direction as those of switches on the metal switch shaft.
42. Attach metal switch shaft coupling to shaft extending from S11 and tighten setscrews.
43. Mount 2 posts (540-9065-003) using hardware removed in step 16. One post mounts in hole near T5 vacated by one of the old posts and the other mounts in the new hole (drilled in step 25) located to the rear of the PTO.
44. Install a 180-pf capacitor C83 (912-2835-000) from XV3 pin 9 to TB14 terminal 2.
45. Install a 68-ohm resistor R8 (745-1303-000) from TB24 to XV4 pin 2.
46. Install a 10-pf capacitor C156 (912-2754-000) from TB24 to the ground lug on J2.
47. Install a 220K resistor R7 (745-1450-000) from TB24 to the ground lug on J2.
48. Install a 20-pf capacitor C157 (912-2766-000) from TB24 to L3 terminal 1.
49. Install a 10-pf capacitor C27 (912-2754-000) from T3 terminal 3 to L3 terminal 1.
50. Install a 27K resistor R90 (745-1412-000) from L3 terminal 1 to L3 terminal 3.
51. Install a 15K resistor R89 (745-1401-000) from S7 terminal 10 to grd-9.

52. Install a length of bus wire (421-2220-000) from XV6 pin 7 to the shield of XV6.
53. Install the 820-ohm 1/2 watt resistor R71 (745-1349-000) from grd-19 to XV5 pin 3, sleeving or insulating the lead on this end.
54. Install an 1800-ohm resistor R91 (745-1363-000) from XV5 pin 8 to grd-19.
55. Install 0.01-uf capacitor C158 (913-3013-000) from XV5 pin 3 to grd-19.
56. Install a length of insulated bus wire (422-4312-000) from XV5 pin 1 to T9 terminal 1.
57. Install a length of bus wire (421-2220-000) from T9 terminal 4 to grd-19.
58. Install a length of bus wire (421-2220-000) from R57 terminal 2 to R57 terminal 3.
59. Install a length of bus wire (421-2220-000) from R57 pin 2 to S13 terminal A.
60. Install a length of bus wire (421-2220-000) from S13 terminal A to S13 terminal 1A.
61. Install a length of bus wire (421-2220-000) from S13 terminal 1A to grd-19.
62. Install a length of insulated bus wire (422-4312-000) from R57 terminal 1 to T9 terminal 5.
63. Install a 680-pf capacitor C159 (912-2989-000) from XV5 pin 1 to grd-19.
64. Install a 2400-pf capacitor C160 (912-3028-000) from T9 terminal 3 to grd-19.
65. Install a 7-pf capacitor C161 (916-0126-000) from XV5 pin 2 to T9 terminal 3.
66. Install a 10-mh rf coil L17 (240-0199-000) from T9 terminal 3 to TB4 terminal 1.
67. Install a 0.01-uf capacitor C162 (913-3013-000) from T9 terminal 6 to XV5 pin 8.
68. Solder all connections made in previous steps.
69. Connect the loose leads of the 1000-ohm resistor R14 and the 0.01-uf capacitor C40 that are located on the front panel side of T10 to T10 terminal 2.
70. Locate the wire that is connected to XV6 pin 5.
71. Connect the wire located in step 70 to T10 terminal 1.
72. Connect the loose lead of the 100K resistor R19 located between T10 and XV7, and connect to T10 terminal 4.
73. Install a 0.01-uf capacitor C163 (913-3013-000) from T10 terminal 4 to TB10 terminal 2.

74. Install a length of insulated bus wire (422-4312-000) from T10 terminal 3 to XV7 pin 1.
75. Solder all connections made in steps 69 through 74.
76. Install 0.001-uf capacitor C106 (913-3009-000) from tube socket XV10 pin 1 to grd-17.
77. Install 0.0015-uf capacitor C-164 (913-3010-000) from pin 3 to pin 4 of switch S11.

NOTE C164 should be omitted if RTTY operation is performed with the MODE switch in CW position.

78. Install shielded wire (425-1005-000), one end of inside lead to pin 4 of S11 and the braid of that end to pin 6 of S11. Route wire body along cable at edge of chassis adjacent to the IF transformers over to the connector of switch S8 (junction of 0.025-uf and 470-uf capacitors, and 100K resistor on switch common). Connect the inside wire lead to pin 6 of S8. Tape cover the braid at the wire end to secure it from exposure.
79. Secure the wire installed in step 78 to the adjacent cable in three convenient locations with cord.
80. Install 8.2K resistor R32 (745-1391-000) in place of the removed (step 5) 12K resistor R32 from TB1-E to grd-4.
81. Remove the head phone jack J6 from the front panel without disconnecting the wires and install the new headphone jack J6 (360-0433-010) in the panel.
82. Install the wiring to the new jack J6 by the following steps and referring to figure 5.
 - a. Disconnect the single wire from lug 1 of the old jack and connect it to lug 2 of the new jack.
 - b. Disconnect the two wires from lug 2 of the old jack and connect the black wire to lug 2 of the new jack and the white-brown-blue wire to lug 1 of the new jack J6.
 - c. Disconnect the orange lead from lug 3 of the old jack and connect it to lug 3 of the new jack.
 - d. Install a new 1K resistor R92 (745-3352-000) to pin 4 from pin 3 of the new jack.
 - e. Install a new 120-ohm resistor R66 (745-1314-000) to pin 4 from pin 5 of the new jack.
 - f. Solder all the new jack J6 connections.

83. Install the new 820-ohm 3.0-watt resistor R59 (747-5358-000) from pin E to pin J of TB2 (replacing R59 removed in step 5).
84. Install the new cover (763-3948-001) for the mechanical filter shield compartment.
85. Install the mechanical filters in their respective sockets, and install the new magnetic shield (553-3453-001) over the filters.
86. Referring to figure 1, across XV8 in upper left corner, install 3-inch length of silver strap (099-3225-000) from GRD-7 to GRD-13. Clean and tin surface, apply strap to connection points and solder securely.
87. Referring to figure 6, install a 3-inch length of silver strap (099-3225-000) from terminal 1 (ground terminal) of J-2 (see figure 1) to the forward edge of the new cover installed in step 85. Clean and tin surface, apply strap to connection points and solder securely.
88. Perform the following alignment procedure:
 - a. Most alignment of the receiver may be accomplished using the crystal calibrator as a signal source and the S-meter as a peak indicator. To provide a variable output attenuator for the calibrator, connect a 0.001-uf capacitor to one end of a 5000-ohm carbon potentiometer. Temporarily connect the free end of the capacitor to tube socket terminal 5 of V1, the crystal calibrator. Connect the rotating contact of the potentiometer to ground. Figure 7 shows the location of adjustments except for the filter input and output trimmer capacitors. These trimmers are located under the chassis adjacent to the mechanical and crystal filters. The rotary ceramic trimmers used in the receiver are at maximum capacity when the large notch is positioned midway between the two mounting screws. Rotation in either direction from this position reduces capacity with minimum being at 180 degrees from maximum.
 - b. Performance of 455-kilocycle if. alignment.
 - (1) Set MODE switch to USB, and center the calibrate signal at 3.7 mc in the if. passband.
 - (2) Adjust calibrator output attenuator to provide S-meter reading of approximately S-3.
 - (3) Adjust the slugs of T9, T10, and T6 for peak meter reading. Reduce calibrator output as necessary to maintain a low meter reading. Repeat T9, T10, and T6 adjustments.

NOTE Adjust T9 using tuning tool (547-2796-002) or equivalent.

- (4) Adjust C122 and C123, FL1 input and output trimmers, for peak meter reading.

- (5) Switch to CW position, and adjust C126 and C127, CW filter input and output trimmers, for peak meter reading. Rock receiver tuning dial to make sure signal is centered in filter passband.
 - (6) Switch to AM position, and adjust top and bottom slugs of T4 and T5 for peak meter reading. Both slugs can be reached through the top of the transformer can and adjusted with a Walsco type 2543 or similar alignment tool.
 - (7) If a signal generator is used for this alignment, remove vfo tube V301, connect generator to pin 2 of V4, and adjust frequency to center of filter passband. Align as outlined above, disconnect generator, and replace V301.
- c. Performance of bandpass if. alignment.
- (1) Set MODE switch to USB, and center the calibrate signal at 3.7 mc in the if. passband.
 - (2) Make two swamping networks by connecting a 0.01-uf capacitor in series with a 1000-ohm resistor and connecting alligator clips to the two remaining leads.
 - (3) Connect one swamping network from T3 primary (terminal 1) to ground and the other from L3 (terminal 1) to ground.
 - (4) Adjust attenuator to provide meter reading of approximately S-3.
 - (5) Peak the secondary of T3 (top of can) using a Walsco type 2543 or equivalent tuning tool.
 - (6) Remove both swamping networks and swamp T3 secondary (terminal 3 to ground). Peak T3 primary (bottom of can), and peak L3.
 - (7) Remove swamping network from T3 secondary. This completes bandpass if. alignment.
 - (8) If a signal generator is used for this alignment, disable the hf crystal oscillator by removing the crystal for the 3.6-mc band. Connect the signal generator to the XTAL OSC OUTPUT jack, and set to 3.055 mc. Tune receiver to the generator signal at approximately 100 on the dial. Align as above, disconnect generator, and replace crystal.

d. Performance of rf circuit alignment.

- (1) Tune to the calibrate signal at 3.7 mc with the MODE switch in either USB or LSB position. Connect a 47-ohm resistor or a dummy load such as the DL-1 to the 75S-3B/C ANT jack. During the following procedures, adjust the calibrator output attenuator as necessary to maintain a meter reading of approximately S-3.
- (2) Set both A (3.8) RF and ANT trimmer capacitors so the large notches point to approximately 2 o'clock when viewed as shown in figure 7. Set the A (3.8) OSC trimmer so the large notch points to the rear of the chassis.
- (3) Set the PRESELECTOR to 2.1 on the logging scale.
- (4) Adjust the OSC, RF, and ANT slugs located on the movable platform for maximum S-meter indication. Adjust the OSC slug first. After making these adjustments, make sure the PRESELECTOR tuning peaks at 2.1 on the logging scale.
- (5) Set BAND switch to 28A, PRESELECTOR to 8.9 on the logging scale, and tune to the calibrate signal at 28.6 mc. Maintain S-3 signal level.
- (6) Adjust E (28) OSC, RF, and ANT trimmer capacitors for peak S-meter reading. Adjust OSC trimmer first.
- (7) Set BAND switch to 21.0 and PRESELECTOR to 7.9 on the logging scale. Tune to calibrate signal at 21.1 mc. Maintain S-3 signal level.
- (8) Adjust D (21) OSC, RF, and ANT trimmers for peak S-meter reading. Adjust OSC trimmers first.
- (9) Set BAND switch to 14.8 and PRESELECTOR to 7.0 on the logging scale. Tune to calibrate signal at 14.9 mc. Maintain S-3 signal level.
- (10) Adjust C (14) OSC trimmer for peak S-meter reading.
- (11) Set BAND switch to 14.2 and PRESELECTOR to 6.6 on the logging scale.
- (12) Adjust C (14) RF and ANT trimmers for peak meter reading. Maintain S-3 signal level.
- (13) Set BAND switch to 7.0 and PRESELECTOR to 3.9 on the logging scale. Tune to calibrate signal at 7.1 mc. Maintain S-3 signal level.
- (14) Adjust B (7) OSC, RF, and ANT trimmers for peak S-meter reading. Adjust OSC trimmer first.
- (15) Disconnect the crystal calibrator output attenuator. This completes rf alignment.

Page 10 of 17
 Revised 5-11-67
 Revised 9-29-67

- (16) If signal generator and rf vtvm are used for this alignment, connect the generator output to the receiver ANT jack. Set generator output to frequencies listed, and align RF and ANT trimmers as outlined in preceding steps. Connect rf vtvm to XTAL OSC OUTPUT jack on bottom side of chassis leaving load plug P1 in place. Align OSC trimmers as indicated, except adjust for peak reading on the vtvm. In step (11), set PRESELECTOR near 6.6 on logging scale at the point where vtvm reading peaks.

e. Performance of if. gain adjustment.

- (1) To set if. gain control R57, a 50-ohm calibrated signal generator is required. Connect the signal generator to the receiver ANT jack, and adjust to 3.0 microvolt output at 14.3 mc. Tune the receiver to the generator signal, and adjust R57 to the point which produces a just-perceptible increase above the no-signal reading on the S-meter. Do not make this adjustment until receiver alignment has been completed.

89. Reassemble the 75S-3B/3C unit reversing the procedure in steps 1, 2 and 3.

90. Enter SBI on information chart (280-3778-010). Adhere the information chart to an appropriate location on the outside of the 75S-3B/3C unit.

PARTS REQUIRED

Modification kit 768-9808-001 consists of the following items:

<u>QTY</u>	<u>DESCRIPTION</u>	<u>SYMBOL</u>	<u>COLLINS PART NUMBER</u>
1	Coil, rf 10-mh	L17	240-0199-000
1	Switch, rotary	S11	259-2533-010
1	Transformer, if	T10	278-0281-000
1	Transformer, if	T9	278-2080-010
3	Solder lugs	Grd-19, 20, 21	304-0317-000
1	Terminal	TB24	306-0981-000
3	Lockwasher, split No. 2		310-0074-000
2	Lockwasher, No. 4		310-0076-000
2	Nut, 2/56		313-0050-000
2	Nut, 4/40		313-0156-000
2	Screw, 4/40		343-0285-000
1	Screw, 2/56 X 3/16		343-0298-000
2	Screw, 2/56 X 1/4		343-0299-000
1	Jack, headphone	J6	360-0433-010

<u>QTY</u>	<u>DESCRIPTION</u>	<u>SYMBOL</u>	<u>COLLINS PART NUMBER</u>
1.0 ft.	Wire, #22 AWG, bus		421-2220-000
1.0 ft.	Wire, #22 AWG, insulated		422-4312-000
2.0 ft.	Cable, shielded		425-1005-000
2	Post, filter cover, 2.0 inch		540-9065-003
1	Cover, filter shield		553-4353-001
1	Shaft, switch, metallic	S11	554-2559-002
1	Resistor, 68-ohm, 1/2-watt	R8	745-1303-000
1	Resistor, 120-ohm, 1/2-watt	R66	745-1314-000
1	Resistor, 820-ohm, 1/2-watt	R71	745-1349-000
1	Resistor, 1.8K, 1/2-watt	R91	745-1363-000
1	Resistor, 8.2K, 1/2-watt	R32	745-1391-000
1	Resistor, 15K, 1/2-watt	R89	745-1401-000
1	Resistor, 27K, 1/2-watt	R90	745-1412-000
1	Resistor, 220K, 1/2-watt	R7	745-1450-000
1	Resistor, 1K, 1/2-watt	R92	745-3352-000
1	Resistor, 820-ohm 3.0-watt	R59	747-5358-000
1	Cover, compartment		763-3948-001
2	Capacitor, 10-pf	C156, C27	912-2754-000
1	Capacitor, 20-pf	C157	912-2766-000
1	Capacitor, 180-pf	C83	912-2835-000
1	Capacitor, 680-pf	C159	912-2989-000
1	Capacitor, 2400-pf	C160	912-3028-000
1	Capacitor, 0.001-uf	C106	913-3009-000
1	Capacitor, 0.0015-uf	C164	913-3010-000
3	Capacitor, 0.01-uf	C158, C162, C163	913-3013-000
1	Capacitor, 7.0-pf	C161	916-0126-000
6.0 in	Strap, silver, ribbon		099-3225-000
1	Chart, information		280-3778-010

The following, not part of the modification kit, may be ordered separately if required:

<u>QTY</u>	<u>DESCRIPTION</u>	<u>COLLINS PART NUMBER</u>
1	Tool, tuning	547-2796-002

The above listed parts may be obtained from Collins Radio Company, Service Parts Department, Cedar Rapids, Iowa 52406.

All orders should specify modification kit 768-9808-001 and reference 75S-3B/3C Service Bulletin No. 1. The parts are available for immediate shipment.

NOTE:

ALL SWITCH WAFERS ARE MOUNTED WITH THEIR TOP FRONT IDENTIFICATION MARKS NEAREST THE CHASSIS AND TOWARD THE FRONT TERMINAL NUMBER 1 IS THE FIRST TERMINAL CLOCKWISE FROM THE IDENTIFICATION MARK

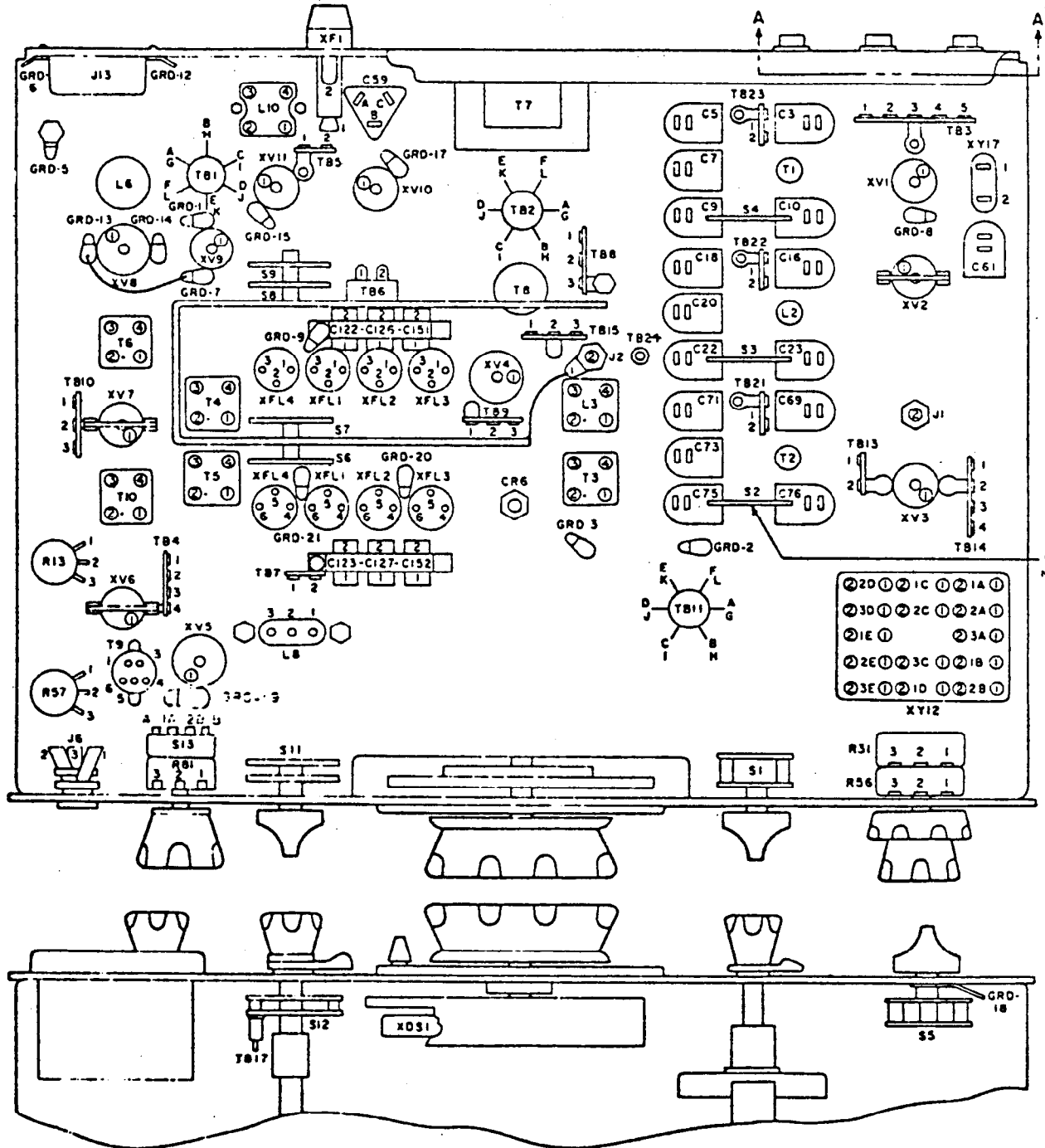
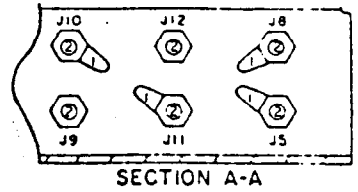

SEE NOTE

Chassis Component Location, Bottom View

Figure 1

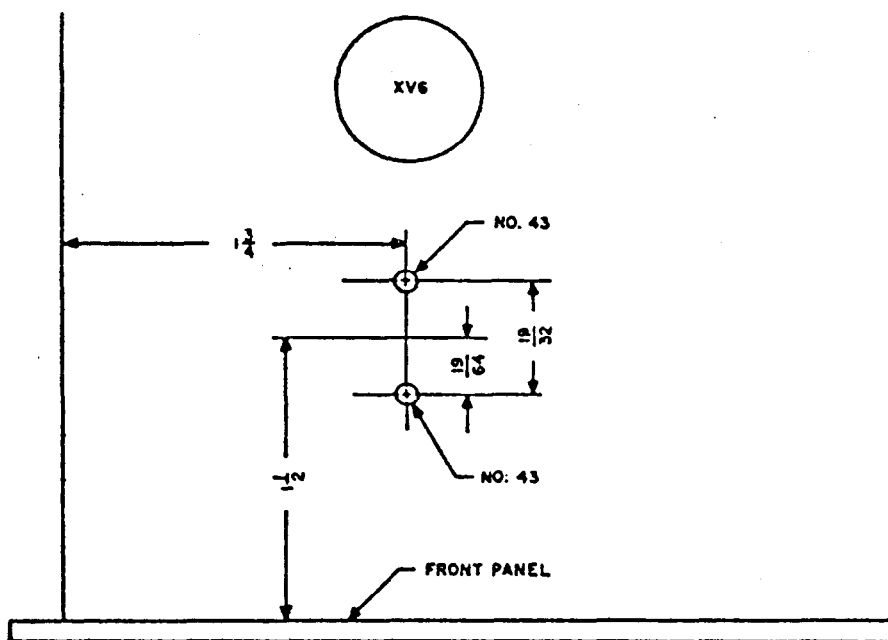

Bottom View of Chassis

Figure 2

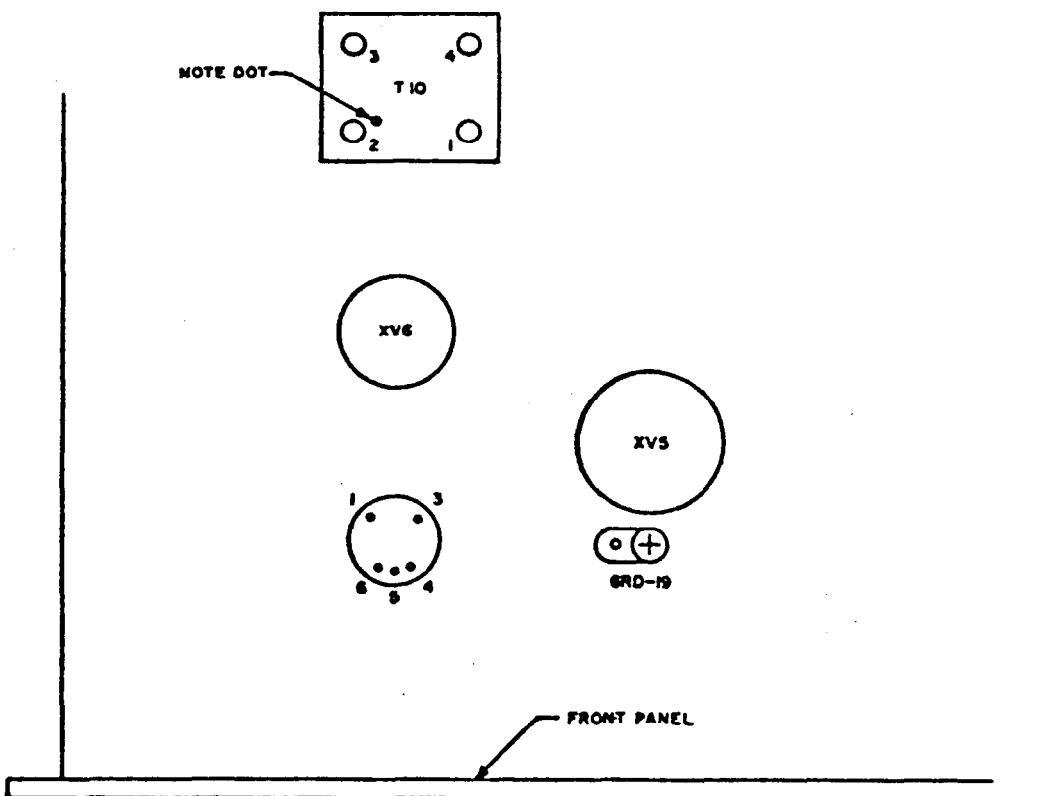

Bottom View of Chassis

Figure 3

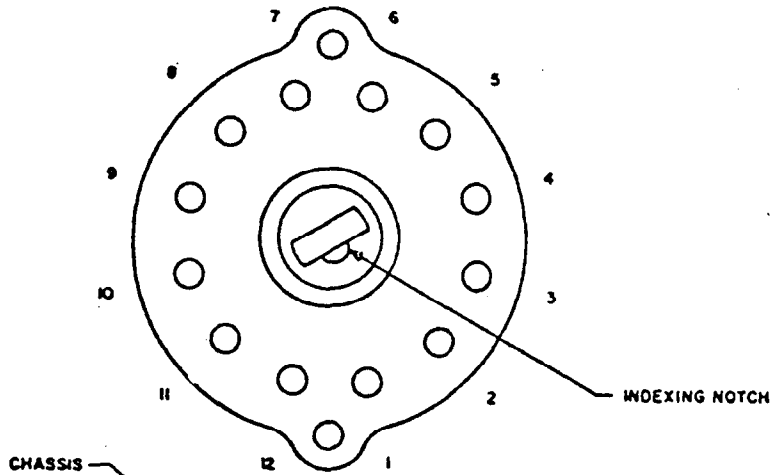

MODE SWITCH SECTION TERMINAL LAYOUT, S7

Rear View, Under Chassis

Figure 4

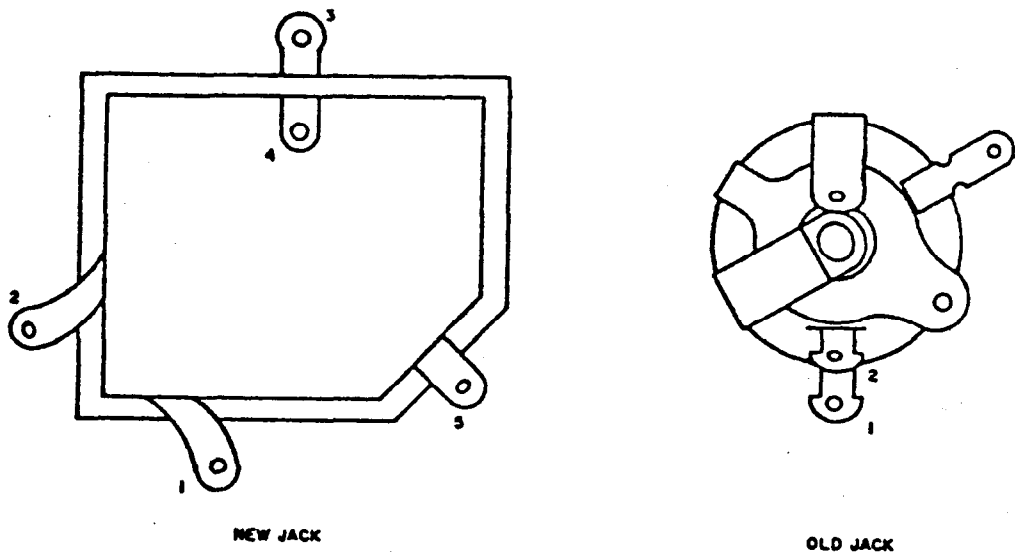

J6, Rear View

Figure 5

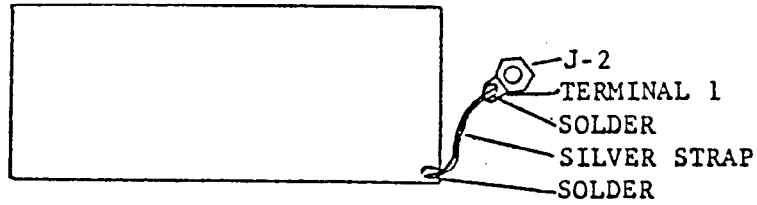

Mechanical Filter Compartment Cover, Bottom View

Figure 6

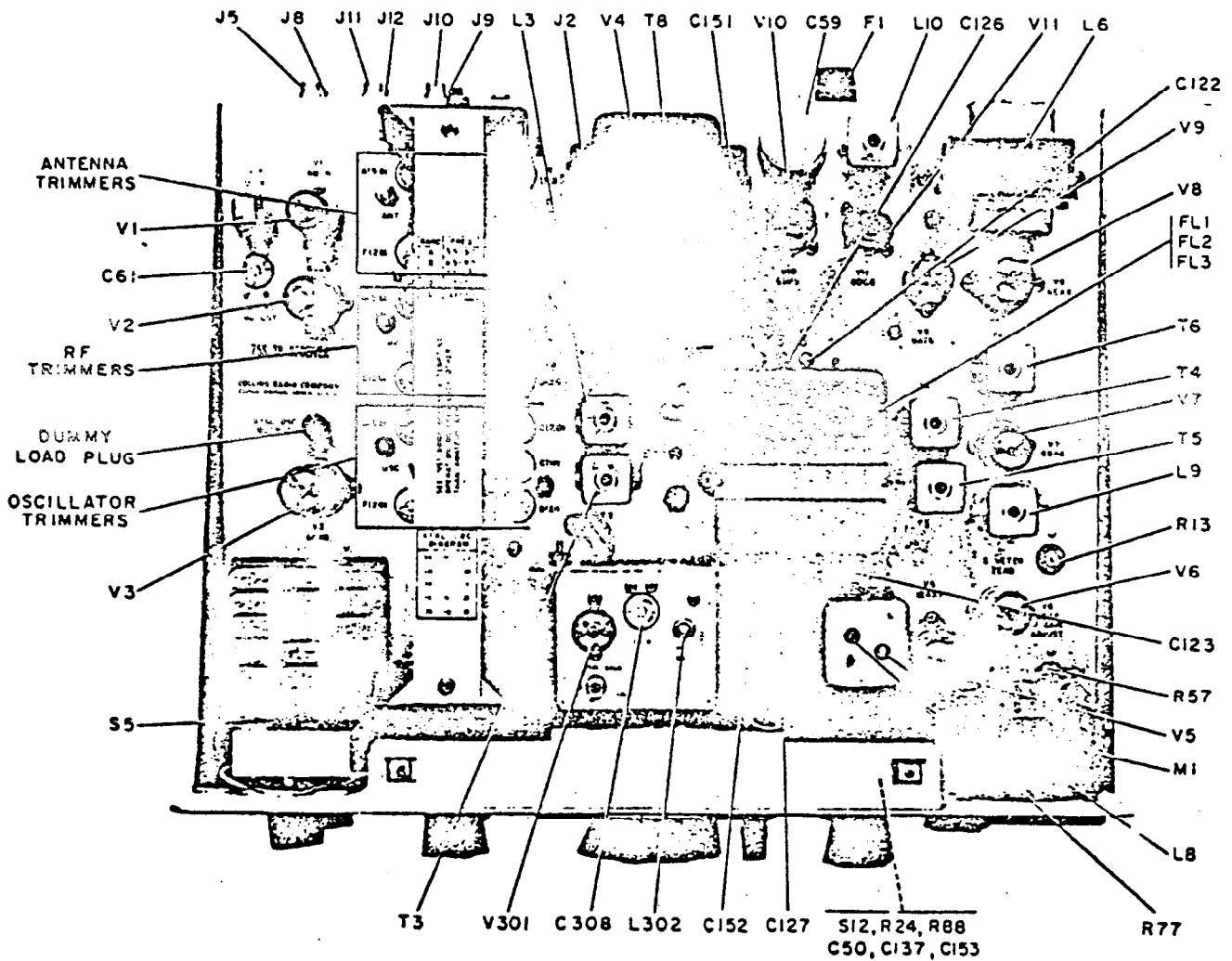

75S-3B/3C Location of Adjustments

Figure 7

2-27-67

Service Bulletin 1

75S-3B/3C

Page 16 of 17

Revised 5-11-67

Revised 9-29-67

THIS PAGE INTENTIONALLY LEFT BLANK

SCHEMATIC DIAGRAM

The Latest Schematic Diagram for the 75S-3B/3C Receiver is contained in the 75S-3B/3C Instruction Book, 7th Edition dated 15 November, 1975.